

Advanced MIMO OFDM Radio

CableFree Antennas – 5.25-5.85 GHz Dual-Pol MIMO Dish 37dBi 180cm Overview



About Wireless Excellence

Founded in 1996 and with headquarters in Oxford UK, Wireless Excellence Limited is a leading designer and supplier of outdoor and indoor Broadband Wireless communication products.

With a complete range of solutions including Radio, Microwave, Millimeter-Wave, Free Space Optics, WiFi and 4G/5G/LTE, customers in over 80 countries have chosen Wireless Excellence as the “one stop shop” solution of choice for dependable wireless networking.

About Our OFDM Range

CableFree OFDM Radio solutions deliver the performance, reliable connectivity, and cost-effectiveness that are crucial to modern wireless broadband networks.

Our scalable wireless platform delivers superior performance even in demanding conditions, with the flexibility and features to enable a wide range of applications.

CableFree OFDM Radio technology combines the best hardware and software technology to ensure best possible network performance.

Specifications

Model	W5GD36P-DP
Frequency Range	5250-5850 MHz
Bandwidth	600 MHz
Gain	37dBi
Horizontal Beamwidth	2°
Vertical Beamwidth	2°
F/B Ratio	>51dB
Isolation	>35dB
V.S.W.R	≤1.5Typ; Max 2.0
Nominal Impedance	50 Ω
Polarization	Vertical and Horizontal
Lightning Protection	Direct Ground
Max. Power	100 W
Connector	2-N Female
Mount	Pole (80-114mm)
Diameter	Φ1.8m (180cm)
Weight	110kg

Product Dimensions

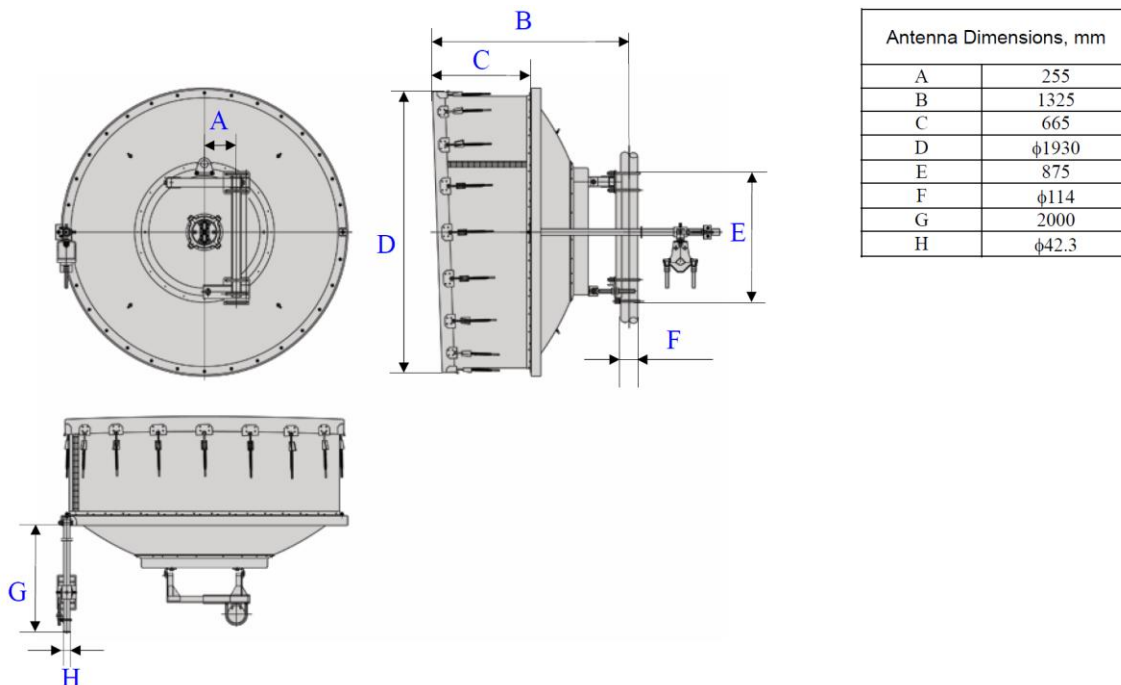

Notes:

Radome is included as standard. Telecom grade design.

RF Design & Engineering Support

Please contact Wireless Excellence before specifying antennas for your application.

Achievable range and data throughput will depend on site conditions such as line-of-sight, Fresnel zone clearance, buildings, and interference from other RF sources.

T: +44 (0)870 495 9169
 E: sales@cablefree.net
 W: www.cablefree.net

Wireless Excellence Limited
 The Oxford Science Park,
 G6, Magdalen Centre
 Robert Robinson Avenue,
 Oxford OX4 4GA