

Released

- Specification -

Ku-band PLL LNB

Internal & External Reference Model

Model No. NJR2845 series

Model No.	RF Frequency	Local Frequency	IF Frequency
NJR2845A series	10.95 to 11.7 GHz	10 GHz	950 to 1,700 MHz
NJR2845B series	11.7 to 12.2 GHz	10.75 GHz	950 to 1,450 MHz
NJR2845C series	12.25 to 12.75 GHz	11.3 GHz	950 to 1,450 MHz
NJR2845D series	11.2 to 11.7 GHz	10.25 GHz	950 to 1,450 MHz
NJR2845G series	12.2 to 12.75 GHz	11.25 GHz	950 to 1,500 MHz

Local Reference Type: Internal / External Reference

Local Stability: L-type(+/- 50 ppm) / H-type(+/- 10 ppm) / S-type(+/- 3 ppm)
/ U-type(+/- 1 ppm) / V-type(+/- 0.5 ppm)

RF Input Interface: Waveguide, WR-75 with Groove

IF Output Interface: N-type / F-type, Female Connector

DC Power Input: IF Output Interface Connector

DC Power Voltage Range: +10 to + 24V

Copyright©**Nisshinbo Micro Devices Inc.****Microwave Business Headquarters**

-Notice of Proprietary Information-

This document and its contents are proprietary to Nisshinbo Micro Devices Inc.

This publication and its contents may not be reproduced or distributed for any other purpose
without the written permission of Nisshinbo Micro Devices Inc.

Those specifications listed in this document are subject to change at any time.



Caution

1. While Nisshinbo Micro Devices Inc. (NISD) continually strives to improve the quality and reliability of our products, failures will occur in microwave products over time. For this reason, it is important that customers fulfill their responsibilities to ensure designed-in safety – including failsafe functions, redundancy, and measures to prevent malfunctions and the spread of fire – in order to avoid injuries, accidents, or social repercussions resulting from the failure of any products related to satellite communications on this website (hereinafter, “the product”). Customers must pay careful attention to ensuring the safety of their equipment.
2. The product is designed and tested to function in accordance with its specifications. Do not use under conditions that deviate from the product specifications included in the delivery specifications. NISD assume no responsibility and shall not be liable for any injuries, accidents, or social repercussions resulting from the product being in a poor or damaged state because it was used under conditions that depart from the specifications.
3. The product is covered by a warranty for one year following delivery unless otherwise stipulated in the contract or delivery conditions. In the event of a failure for which NISD are responsible occurring during the warranty period, NISD undertake to repair or replace the product free of charge. Note, however, that the warranty does not cover failures such as those listed here (see bullets below), even if they occur within the warranty period. In addition, in the case of a product being repaired or replaced by us, the starting date for the warranty period is still the original delivery date of the product.
 - Failure due to the product being used in conditions other than those stipulated in the data sheet, specification sheet, etc.
 - Failure due to modifications or repairs carried out by some entity other than our company
 - Failure determined to be the result of unsuitable maintenance or replacement of a consumable item that requires due maintenance
 - Failure due to circumstances that were unforeseeable given the scientific/technological standards at the time of shipment
 - Other failures due to external factors such as fire, earthquake, flood and power supply anomalies for which NISD are not responsible

In addition, the product warranty is limited to the provision of repair services or replacement at no cost. It does not cover secondary damage (to equipment, business opportunities, profits, etc.) or any other damage that may have resulted from failure of the product.

4. The product must be handled appropriately to ensure its continued reliability. Since it can be damaged by the intrusion of water, dust, oil, chemicals, etc., it must be given appropriate protection. Even in the case of a product with an airtight construction, avoid using it in an environment that exceeds the stated levels of waterproofing/dustproofing. Also, be sure to use connectors and waveguides properly.
If replacement parts such as fans are included, proper maintenance is necessary. To maintain product performance and functionality, it is necessary to conduct inspections and maintenance at appropriate intervals and exchange replacement parts when necessary. Improper inspections or maintenance may result in failure.
In addition, the warranty does not cover the use of the product in areas where salt damage can be expected or where there is a substantial presence of corrosive gases such as Cl₂, H₂S, SO₂, and NO₂. If the product is to be used in such areas, at the time of installation you must take appropriate steps to protect the product.
5. If the product is to be used with equipment/systems that must meet special quality and reliability standards (aerospace equipment, medical equipment, power generation control equipment, automotive/railway transportation equipment, safety equipment, disaster prevention and security equipment, etc.), please consult with our sales staff in advance.
6. Some products contain gallium arsenide (GaAs), classified as a harmful substance. To avoid danger, do not incinerate, crush, or chemically treat the product in such a way that gases or dust are released. When disposing of the product, comply with all applicable laws and regulations and do not treat it as general industrial waste or household waste.
7. When exporting a product or technology, observe export laws and regulations such as those governing foreign exchange and foreign trade, and obtain any necessary licenses for export, service transactions, etc.
NISD request that you do not use our products or the technical data published on this website for developing weapons of mass destruction or for any other military purposes or applications.
8. The product specifications in this document are subject to change without notice. If you are considering using a product, delivery specifications must first be settled.

* Above Specifications are subject to change without notice.

Scope

This LNB is designed for the low noise amplifier and block downconverter intended for the satellite communication data downlink application in Ku-band. It is combined a 2-stage HEMT amplifier and a block downconverter with a phase locked local oscillator (10 GHz, 10.25 GHz, 10.75 GHz, 11.25 GHz, or 11.3 GHz) which is synchronized with either internal high stability TCXO reference or external 10MHz reference.

The LNB receives an RF signal (Ku-band: frequency divided by region band from the 10.75 to 12.75 GHz) as input, downconverts from the RF signal to an IF signal (L-band: 950 to 1,700 MHz), and outputs the IF signal. It is operated by +24 V DC power (range: +10 to +24 V) input.

The LNB comes in a single, weatherized housing rated for outdoor use, and has a WR-75 waveguide flange with groove as RF input and an either an N-type or F-type female connector as IF output.

Internal Reference Model

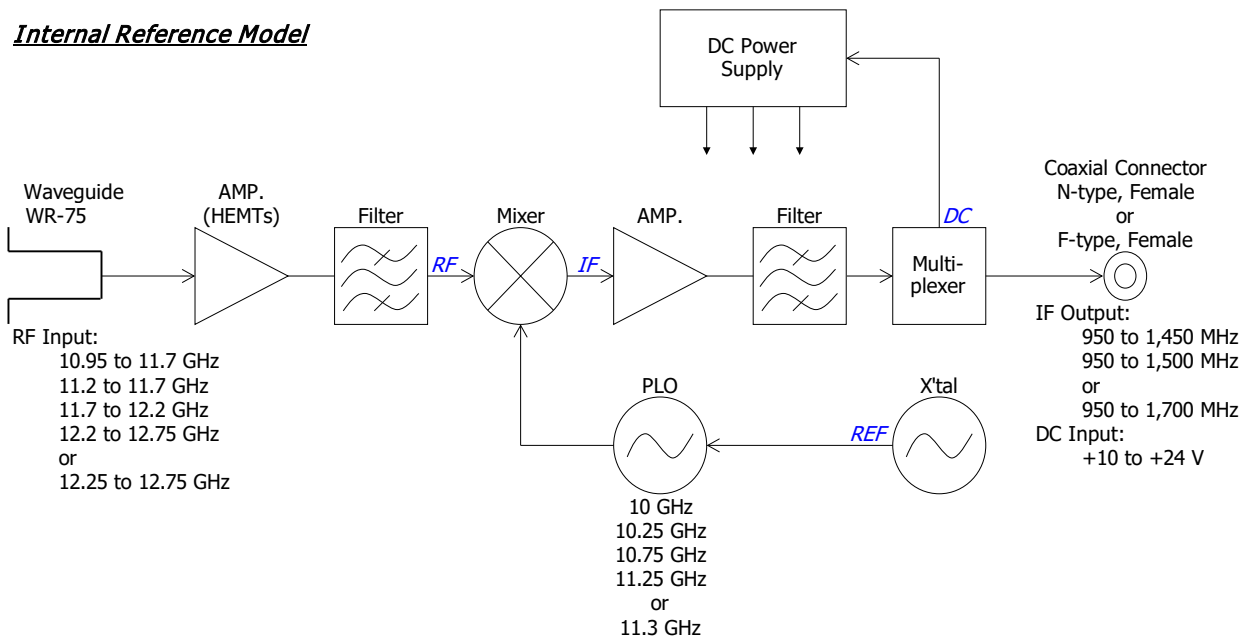

External Reference Model

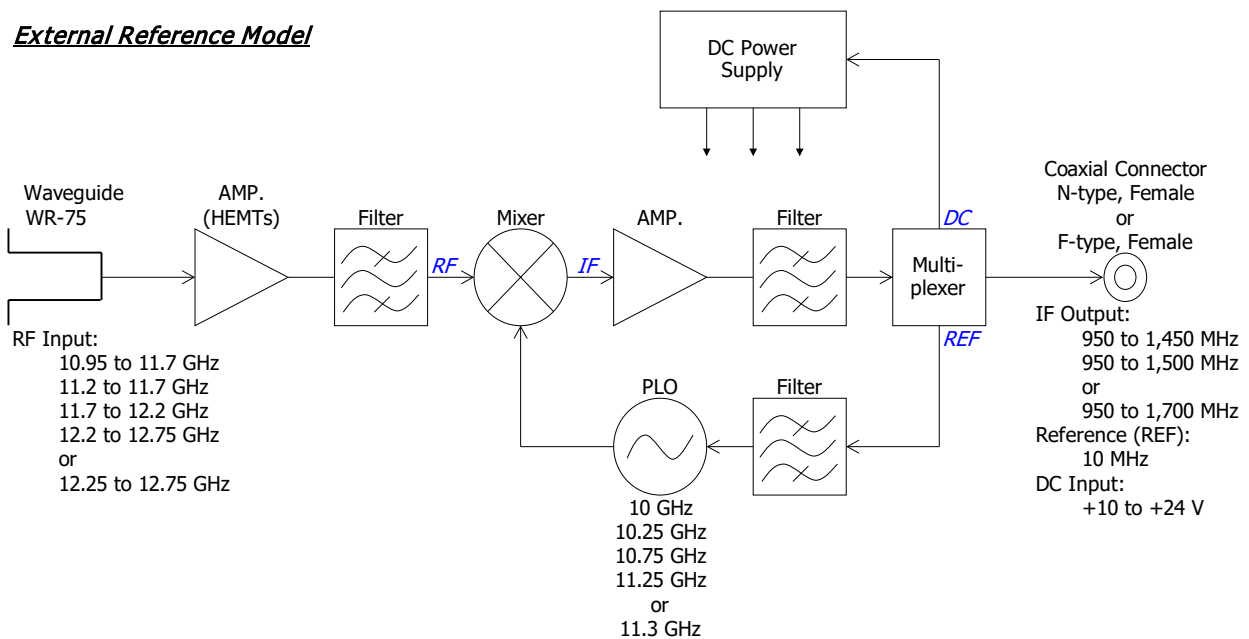

Fig.2 Functional Block Diagram

* Above Specifications are subject to change without notice.

Series Model Number

- Numbering System

N J R 2 8 4 5 A H F

IF Interface Connector

F: F-type (75 ohms), Female Connector

N: N-type (50 ohms), Female Connector

Local Stability Line-up

L: Internal Reference, Local Stability: +/- 50 ppm, L-type

H: Internal Reference, Local Stability: +/- 10 ppm, H-type

S: Internal Reference, Local Stability: +/- 3 ppm, S-type

U: Internal Reference, Local Stability: +/- 1 ppm, U-type

V: Internal Reference, Local Stability: +/- 0.5 ppm, V-type

E: External Reference, E-type

RF Frequency Band

A: 10.95-11.7GHz NJR2837/NJR2937

B: 11.7-12.2GHz NJR2835/NJR2935

C: 12.25-12.75GHz NJR2836/NJR2936

D: 11.2-11.7GHz NJR2839/NJR2939

G: 12.2-12.75GHz NJR2934

Product Series Number

* Above Specifications are subject to change without notice.

1. Electrical Specifications

#	Items	Specifications
1.1.	Absolute Maximum Rating [RF Input Power] [Supply Voltage]	-10 dBm (@ CW) +28 V DC
1.2.	Input RF Frequency Range	
	<Model No. NJR2845A>	10.95 to 11.7 GHz
	<Model No. NJR2845B>	11.7 to 12.2 GHz
	<Model No. NJR2845C>	12.25 to 12.75 GHz
	<Model No. NJR2845D>	11.2 to 11.7 GHz
	<Model No. NJR2845G>	12.2 to 12.75 GHz
1.3.	Noise Figure @ +25 °C	0.8 dB typ., 1.0 dB max.
1.4.	Output IF Frequency Range	
	<Model No. NJR2845A>	950 to 1,700 MHz
	<Model No. NJR2845B>	950 to 1,450 MHz
	<Model No. NJR2845C>	950 to 1,450 MHz
	<Model No. NJR2845D>	950 to 1,450 MHz
	<Model No. NJR2845G>	950 to 1,500 MHz
1.5.	Conversion Gain @ +25 °C	52 dB min., 57 dB typ.
1.6.	Conversion Gain Ripple @ +25 °C	2 dBp-p max. at any 50 MHz segments.
1.7.	Conversion Gain Flatness over Frequency @ +25 °C	5 dBp-p max. over Receive Bandwidth
1.8.	Output Power @ 1dB G.C.P. (P1dB) @ +25 °C	0 dBm min.
1.9.	Output Intercept Point of 3 rd Order Intermodulation	+5 dBm min.
1.10.	Tx Signal Immunity [Gain Change] [Noise Figure Change]	0.2 dB max. 0.1 dB max. at -20 dBm Tx Input (13.75 to 14.5 GHz)
1.11.	Local Oscillator Frequency	
	<Model No. NJR2845A>	10 GHz nom.
	<Model No. NJR2845B>	10.75 GHz nom.
	<Model No. NJR2845C>	11.3 GHz nom.
	<Model No. NJR2845D>	10.25 GHz nom.
	<Model No. NJR2845G>	11.25 GHz nom.

* Above Specifications are subject to change without notice.

#	Items	Specifications
1.12.	Local Oscillator Frequency Stability * Initial Setting Error and Temperature Stability (-40 to +60 °C)	
	<L-type Model>	+/-50 ppm max.
	<H-type Model>	+/-10 ppm max.
	<S-type Model>	+/-3 ppm max.
	<U-type Model>	+/-1 ppm max.
	<V-type Model>	+/-0.5 ppm max.
	<E-type Model>	Same as External Reference Stability
1.13.	L.O. Phase Noise (SSB)	-50 dBc/Hz typ. @ 100 Hz -70 dBc/Hz typ. @ 1 kHz -75 dBc/Hz typ. @ 10 kHz -85 dBc/Hz typ. @ 100 kHz -105 dBc/Hz typ. @ 1 MHz In case of E-type, depend on External Reference Stability
1.14.	Requirement for External Reference (Only E-type Specified)	
	[Input Port]	IF Output Interface Connector (Combine reference with IF Signal)
	[Frequency]	10 MHz (sine-wave)
	[Input Power]	-10 to 0 dBm @IF Output connector
	[Phase Noise]	-125 dBc/Hz max. at 100 Hz -135 dBc/Hz max. at 1 kHz -140 dBc/Hz max. at 10 kHz (Input Condition)
1.15.	Spurious	a) -120 dBm max. at input, Fixed frequency spur, unrelated to test CW signal. b) -40 dBc typ., -30 dBc max. with test CW signal -10 dBm IF output
1.16.	Local Oscillator Leakage Levels	-40 dBm max. at the IF Output Connector. -60 dBm max. at the RF Input Flange.
1.17.	Image Rejection	40 dB min.
1.18.	Input V.S.W.R.	2.5 : 1 typ.
1.19.	Output Impedance	
	<N-type Model>	50 ohms nom
	<F-type Model>	75 ohms nom.
1.20.	Output V.S.W.R.	2.3 : 1 max.

* Above Specifications are subject to change without notice.

NJR2845 series

#	Items	Specifications
1.21.	Power Requirement	
	[Input Port]	IF Output Interface Connector (Combine DC Power with Output IF Signal)
	[Input Voltage]	+10 to +24 VDC
	[Current Drain]	
	<L/H/S/U/V-type>	170 mA max.
	<E-type>	200 mA max.

* Above Specifications are subject to change without notice.

2. Mechanical Specifications

#	Items	Specifications
2.1.	RF Input Interface	Waveguide, WR-75 (with Groove)
2.2.	IF Output Interface	
	<N-type Model>	Coaxial Connector , N-type Female - 50 ohms
	<F-type Model>	Coaxial Connector , F-type Female - 75 ohms
2.3.	Dimension & Housing without Interface Connector	82.2 (L) x 40 (W) x 40 (H) mm [3.24" (L) x 1.57" (W) x 1.57" (H)]
2.4.	Weight	
	<F-type Model>	210 g [0.46 lbs]
	<N-type Model>	240 g [0.53 lbs]

3. Environmental Specifications

#	Items	Specifications
3.1.	Temperature Range (Ambient)	
	[Operating]	-40 to +60 °C
	[Storage]	-40 to +80 °C
3.2.	Humidity	0 to 100 % RH
3.3.	Altitude	15,000 feet (4,572 m)
3.4.	Vibration (Survival)	5 G [49.03 m/s ²] (3 axis, 50 Hz)
3.5.	Shock (Survival)	15 G [147.1 m/s ²] (3 axis)
3.6.	Waterproof / Dustproof (IP Code Rating)	IP 67
3.7.	Regulations	EU Directive (CE Marking) RE - 2014/53/EU EMC - 2014/30/EU RoHS - 2011/65/EU + (EU)2015/863 Safety: EN62368-1, EN60950-22
3.8.	MTBF (by Method of Parts Count Reliability Prediction)	150,000 hours and more at +60 °C as Design Condition

* Above Specifications are subject to change without notice.

4. Outline Drawing

4.1. F-type Model (e.g. NJR2845AEF)

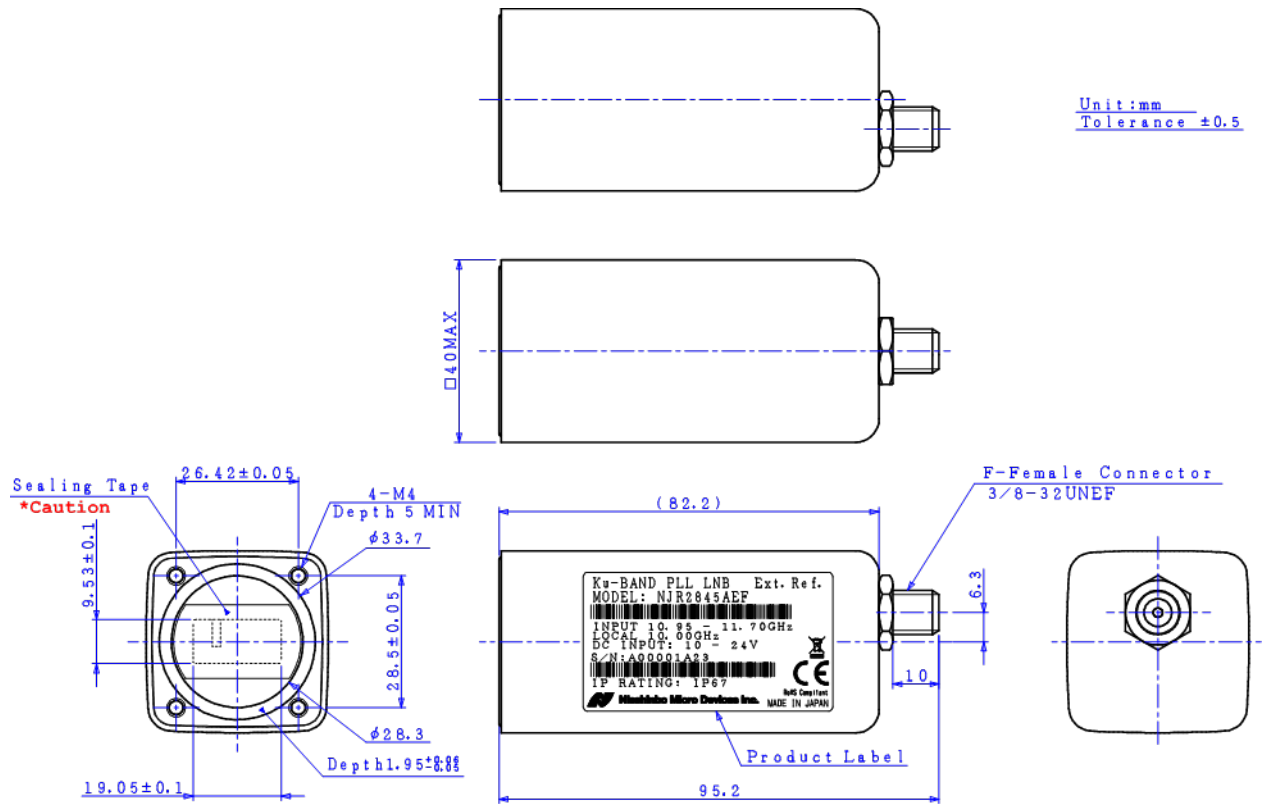

CAUTION

Items	Description
Sealing Tape	Do not remove the sealing tape on the waveguide. If the sealing tape is removed, it will lose the performance of waterproof and also it will become out-of-warranty.

* Above Specifications are subject to change without notice.

4.2. N-type Model (e.g. NJR2845AEN)

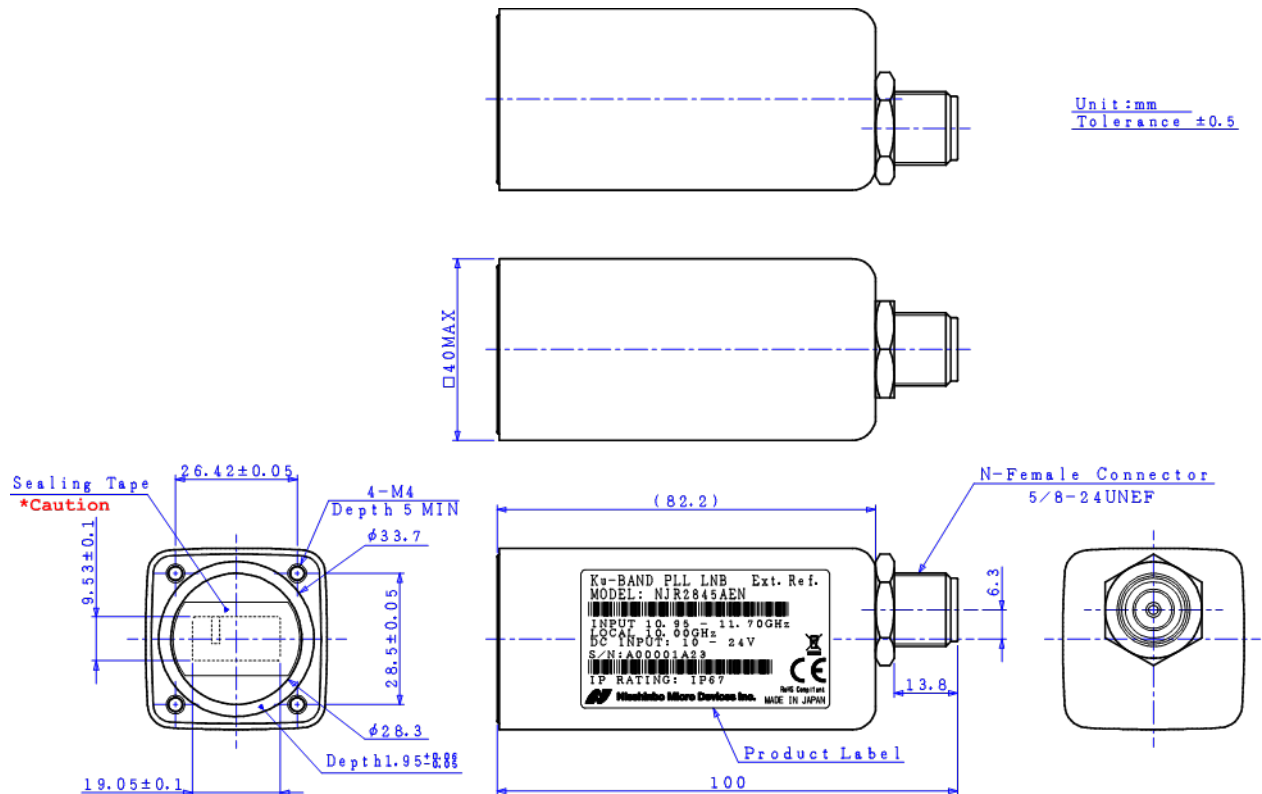

CAUTION

Items	Description
Sealing Tape	<u>Do not</u> remove the sealing tape on the waveguide. If the sealing tape is removed, it will lose the performance of waterproof and also it will become out-of-warranty.

* Above Specifications are subject to change without notice.

5. Label

5.1. Label Outline (e.g. NJR2845AEF)

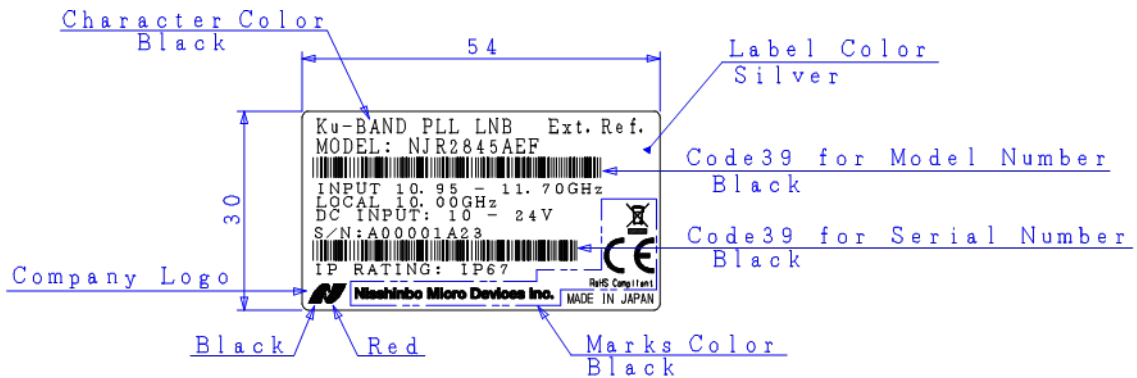

UNIT:mm

5.2. Definitions

Serial Number (OSSSSSRYM) - ALPHANUMERIC (9 characters)

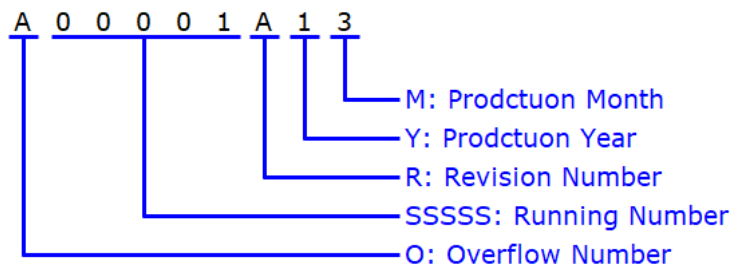

O: Overflow Number - ALPHABET (1 character)

"A" to "T" except "I" and "O", e.g.: A99999 ⇒ B00001

"V" to "Z": Specified Numbers

SSSS: Running Number - NUMBER (5 digits)

"00001" to "99999"

R: Revision Number - ALPHABET (1 character)

"A" to "T" except "I", "O", and "U"

Y: Production Year - NUMBER (1 digit)

"0" to "9", Last Digit of Calendar Number

e.g.: 2021:"1", 2022:"2", 2023:"3".....

M: Production Month - ALPHANUMERIC (9 characters)

"1" to "9", "X" as October, "Y" as November, "Z" as December

* Above Specifications are subject to change without notice.

6. Package

6.1. Individual Package / Shipping Package

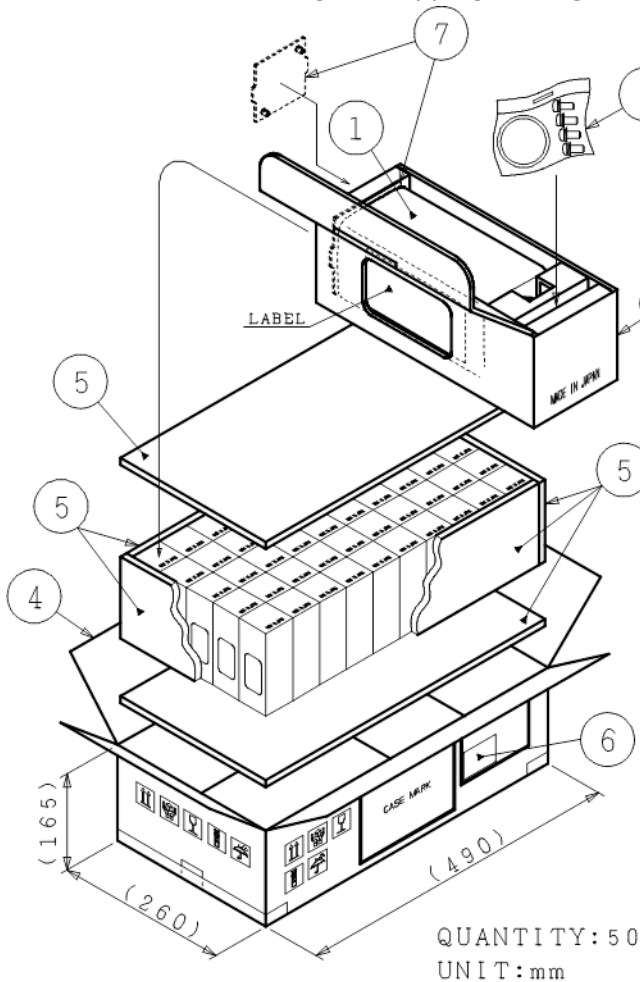

- ①: LNB
- ②: Accessory
 - O-RING
 - Screw (M4×12 4 Pieces SUS, SW and W)
- ③: Single Wall Corrugated Fibreboard
- ④: Double Wall Corrugated Fiberboard
- ⑤: Polystyrene Foam For Package Cushioning
- ⑥: Package Label (MODEL No., QUANTITY)

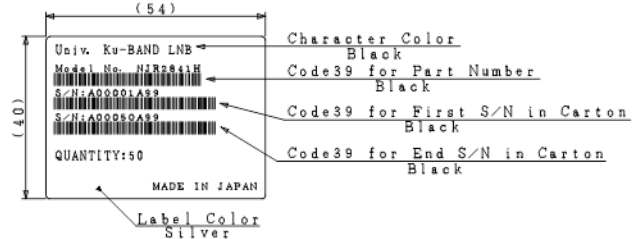

- ⑦: Polypropylene Flange Cover

Pictorial Marking for Handling of Goods



THIS WAY UP



FRAGILE



HANDLE WITH CARE



LAYERS LIMIT: 7



KEEP DRY

* Above Specifications are subject to change without notice.

6.2. Enclosed Accessories

- O-ring, Qty (1), for Waveguide Flange
- Screw, Qty (4), M4 x 12 mm, Phillips Head with Spring Washer and Flat Washer, SUS

* Above Specifications are subject to change without notice.

7. Handling Precautions

7.1. DANGER



This statement indicates an imminently hazardous situation which, if not avoided, will result in death or serious injury.

Items	Description
Input Voltage	Only input a DC voltage within the range indicated in specifications. <u>Do</u> operate with the input voltage range between +10 and +24 V DC power. When applying higher voltage than specifications (+28 V as maximum value of input voltage in power requirement), it will not only cause this unit failure, but it may also result in <u>electric shock</u> and <u>fire</u> .
Disassembling	<u>Do not</u> disassemble the unit. Disassembling will not only cause this unit failure, but it may also result in <u>electric shock</u> .

7.2. CAUTION



This statement indicates a potentially hazardous situation which, if not avoided, could result in minor or moderate injury. The statement may also be used to indicate other unsafe practices or risks of property damage.

Items	Description
Disposal	This unit contains gallium arsenide (GaAs), classified as a harmful substance. To avoid danger, <u>do not</u> incinerate, crush, or chemically treat the unit in such a way that gases or dust are released. When disposing the unit, comply with all applicable laws and regulations and do not treat it as general industrial waste or household waste.

7.3. NOTE



This statement is used to notify of installation, operation, or maintenance information that is important, but not hazard-related.

Items	Description
Torque Management	<u>Do not</u> tighten with excessive torque when attaching screws/bolts and connectors. The following value as tighten torque is recommended. <ul style="list-style-type: none"> ■ Screws/Bolts - M4: 1.15 to 1.4 N·m ■ IF Connector (N-type / F-type): 0.68 to 1.13 N·m

* Above Specifications are subject to change without notice.

Items	Description
Weatherproof	<p>The unit mounted in outdoor should be conducted with adequately weatherproof procedure.</p> <p>Do seal all of cable connection points from the connector to the cable sheath by usage of self-amalgamating tape.</p> <p>Ensure the waveguide connection is properly assembled with the enclosed o-ring gasket as accessories. The o-ring gasket is full-type and it is assumed to connect the unit to a flat waveguide flange.</p>
Waveguide Sealing Tape	<p><u>Do not</u> remove the sealing tape on the waveguide.</p> <p>If the sealing tape is removed, it will lose the performance of waterproof and also it will become out-of-warranty.</p>
Input Voltage	<p><u>Do</u> operate with the input voltage range between +10 and +24 V DC power.</p> <p>Avoid applying more than the maximum voltage in this range (including ripple voltage) under any conditions.</p>
Input RF Signal Power	<p><u>Do not</u> supply the input RF signal over the absolute maximum rating indicated in specifications (-10 dBm @ CW / +10 dBm @ Pulse).</p>
Input 10MHz Signal Power	<p>The 10 MHz reference signal should be supplied with the range between -10 and 0 dBm with sine-wave for correctly operation.</p> <p><u>Do not</u> supply the signal level of more than +13 dBm.</p>
High Temperature Operation	<p>It may cause damage and/or degradation of reliability / lifetime to operate the unit in a condition where the ambient temperature exceeds the maximum value, <u>+60 °C</u>, at operating temperature described in the specifications.</p>
Vibration / Shock	<p>When vibration and/or shock impact exceeding the conditions described in the specifications is applied, internal parts may be damaged.</p>
Warranty	<p>The unit is covered by a warranty for one(1) year following delivery unless otherwise stipulated in the contract or delivery conditions.</p> <p>Repairs may be possible under payment of charge even for the unit whose warranty period has expired.</p> <p>Opening, removing, disassembling and modifying any parts and components (including the product label, sealing tape and screws) without fan equipment will immediately void the warranty.</p> <p>In any case, the unit of invalid warranty cannot be repaired.</p>

* Above Specifications are subject to change without notice.

8. Instructions Manual

8.1. Descriptions

This section describes the information of connectors and etc.

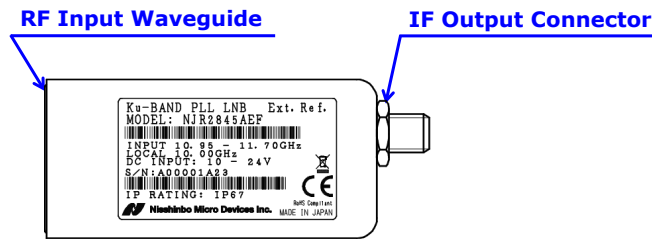

Items	Description	Purpose
RF Input Waveguide	Waveguide: WR-75 Flange: Square Cover Grooved (Equivalent to PBR 120)	The LNB receives an RF signal (Ku-band: frequency divided by region band from the 10.75 to 12.75 GHz) via this waveguide.
IF Output Connector	F-type Female Coaxial Connector, 75 Ohms OR N-type Female Coaxial Connector, 50 Ohms	The LNB outputs an IF signal of L-band (950 to 1,700 MHz) and requires to supply +10 to +24 V DC power via this connector. In case of E-type, the external 10MHz reference requires to be input.

8.2. Connection and Installation

This section describes basic installation for the LNB.

8.2.1. Mounting Configuration

The Unit can be mounted with OMT or the waveguide filter of the satellite antenna.

When mounting with the OMT or the waveguide filter, the following steps should be complied:

- Step 1: Verify that the groove on the waveguide flange for a gasket is clean. The enclosed o-ring gasket as accessories is full-type and it is assumed to connect the LNB to a flat waveguide flange (non-grooved waveguide flange). Insert the o-ring gasket the groove as shown in the figure on the right. The o-ring gasket and flange groove dimensions is customized and optimized for this LNB; therefore any other o-ring gasket than the enclosed accessory is not permitted for using. Do not remove the sealing tape on the waveguide.

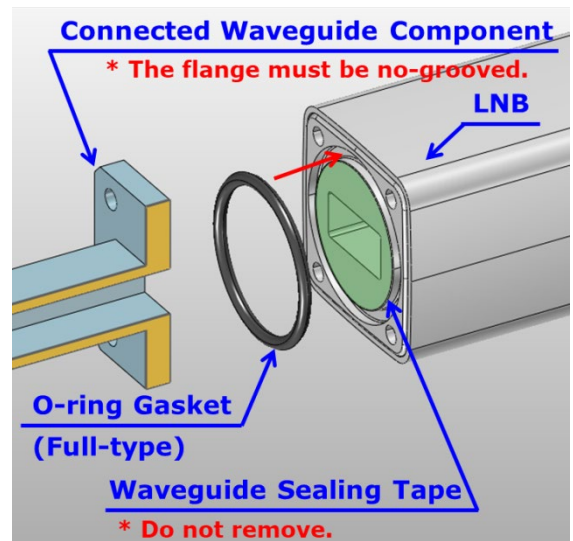

* Above Specifications are subject to change without notice.

Step 2: Secure the OMT or the filter to the LNB by tightening the enclosed Phillips head screws (M4 x 12 mm) with 1.15 to 1.4 N·m torque as shown in the figure below, when the thickness of the flange of the OMT or filter is assumed to be 5 to 7 mm. The enclosed washers as accessory must be inserted to bolts before tightening bolts. When the thickness is other than 5 - 7 mm, the appropriate length screws or bolts based should be prepared on the table on the right.

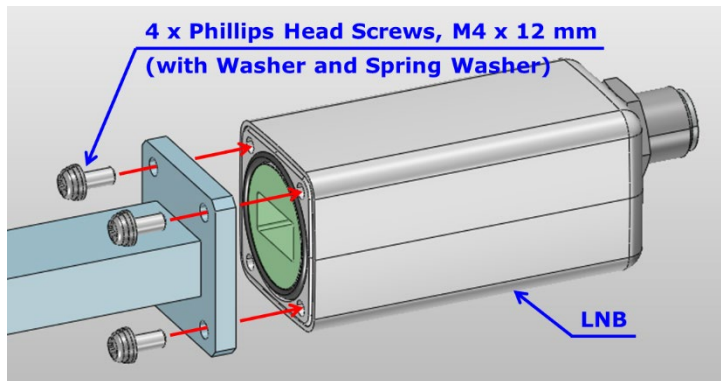

Flange Thickness of OMT/Filter	Screw Length
3 to 5 mm	10 mm
5 to 7 mm	12 mm
7 to 9 mm	14 mm
9 to 11 mm	16 mm

8.2.2. Connecting Coaxial Cable

The LNB is connected the modem with a coaxial cable, and requires to supply +10 to +24 V DC power and a 10 MHz reference from the modem.

The connection of coaxial cable should be complied with the following steps:

Step 1: Connect the coaxial cable with the N or F-type male connectors to the coaxial connector equipped with the LNB which is shown in the figure on the right below under 0.68 to 1.13 N·m tighten torque.

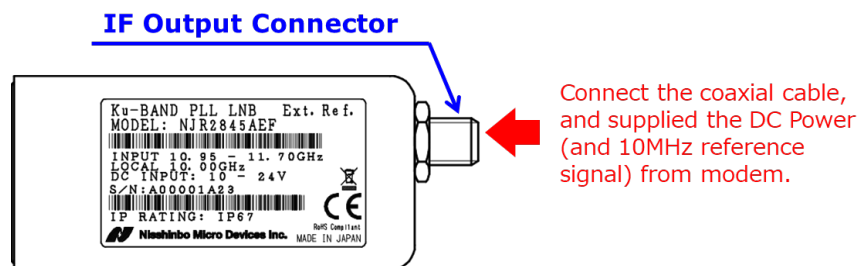

Step 2: Use self-amalgamating tape to seal connector and cable entry points from the connector to the cable sheath.

Do not power on the modem before finishing all of steps of Connecting Coaxial Cable.

8.2.3. Start-up

Start-up will be immediately performed with the following step:

Step: Power on the modem and supply the DC voltage and 10 MHz reference from modem.

* Above Specifications are subject to change without notice.



DANGER

- ✓ Only input a DC voltage within the range indicated in specifications.
Do not operate with the input voltage range between +10 and +24 V DC power.
When applying higher voltage than specifications (+28 V as absolute maximum rating), it will not only cause this unit failure, but it may also result in electric shock and fire.



NOTE

- ✓ The 10 MHz reference signal should be supplied with the range between -10 and 0 dBm with sine-wave for correctly operation.
Do not supply the signal level of more than +13 dBm.
- ✓ Do not power on the modem before finishing all of steps of Connecting Coaxial Cable.
- ✓ The LNB must be adequately weatherproofed to place in outdoor.
 - Ensure that the waveguide joint is properly sealed with the enclosed o-ring gasket.
 - Do seal all of cable connection points from the connector to the cable sheath by usage of self-amalgamating tape.

* Above Specifications are subject to change without notice.