

# 10 MHz Recovery Oscillator / DC Inserter

10 MHz Recovery  
oscillator enhances  
Phase Noise Performance

The 10 MHz Recovery oscillator is used to enhance the Phase Noise Performance of a 10 MHz Reference Signal, thus "cleaning" a noisy incoming 10 MHz signal. Ideal for use together with LNB or BUC. L-Band loopthrough, separate DC input and dual 10 MHz outputs.

The Recovery Oscillator latches on to the incoming 10 MHz and it will not take care of stability issues of the incoming signal. Hence the feedback loop filtering characteristics is set up to give a "cleaning effect" of 50% at 10 Hz and 100% from 100 Hz and above.

Very Low power consumption OCXO.

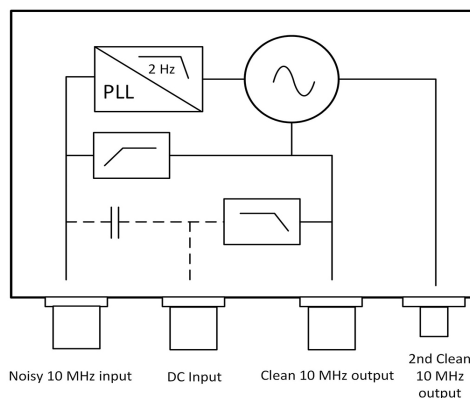
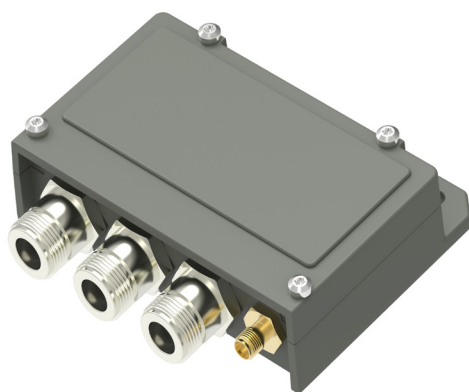

## TECHNICAL SPECIFICATIONS

MODEL:	LREC - 10 MHz Recovery Oscillator
10 MHz Input Frequency Range	10 MHz $\pm$ 0.2 ppm
10 MHz Output Frequency Stability	Depending on stability of input frequency source, max. $\pm$ 0.5ppm @ loss of 10 MHz input
10 MHz input level	-10 dBm to +7 dBm
L-Band Frequency Range	950 - 2150 MHz
Maximum load	800 mA @ DC output
DC Input	+10 to +28 V (optional via sep. RF connector or pigtail 2 meter)
DC block	By request for Input and Output
IF Insertion Loss	1 dB @ 950-2150 MHz max.
Return Loss 10 MHz Input	> 20 dB
Return Loss 10 MHz Output	> 20 dB
Return Loss L-band Input / Output	min. 10dB, typ. 15 dB
10 MHz Harmonic Suppression	> 70 dBc (L-Band output), > 40 dBc (separate 10 MHz output)
Temperature Range	-40 to +80°C
Ingress Protection Code	IP 67
Connectors	F-type 75 $\Omega$ / N-type 50 $\Omega$ / SMA-type 50 $\Omega$
22 kHz Bypass (standard)	Through receiver or external source, n/a with DC Block IN or OUT
Output Frequency	10 MHz, Sinewave
Output Level	+6 dBm, $\pm$ 1 dB
2nd Output level	+6 dBm, $\pm$ 1 dB
Frequency Stability	$\pm$ 20 ppb @ 0 to +50°C, $\pm$ 50 ppb @ -40 to +85°C
Calibration Tolerance	$\pm$ 10 ppb @ 25°C
Aging	$\pm$ 500 ppb max. @ 10 years
Phase Noise	-90 dBc @ 1 Hz, -120 dBc @ 10 Hz, -142 dBc @ 100 Hz, -155 dBc @ 1 kHz, -163 dBc @ 10 kHz (max. values)
Current Consumption	100 mA warm up 1 min., 35 mA steady state typ.
Dimensions	96 x 28 x 89 mm ( N connectors ) ( for drawing, see <a href="http://www.smw.se">www.smw.se</a> )
Weight	230 g (SMA), 270 g (N), 396 g (N + pigtail)
Options	Factory calibration, +7 dBm output (one output), DC input via sep. RF connector or pigtail 2 meter

Above parameters are generic product family values. For part number specific min./max. values, please consult us.

Specifications are subject to change without notice. Products from Swedish Microwave AB are made for commercial use.

Rev.01-22-5B

# 10 MHz Recovery Oscillator/DC inserter examples

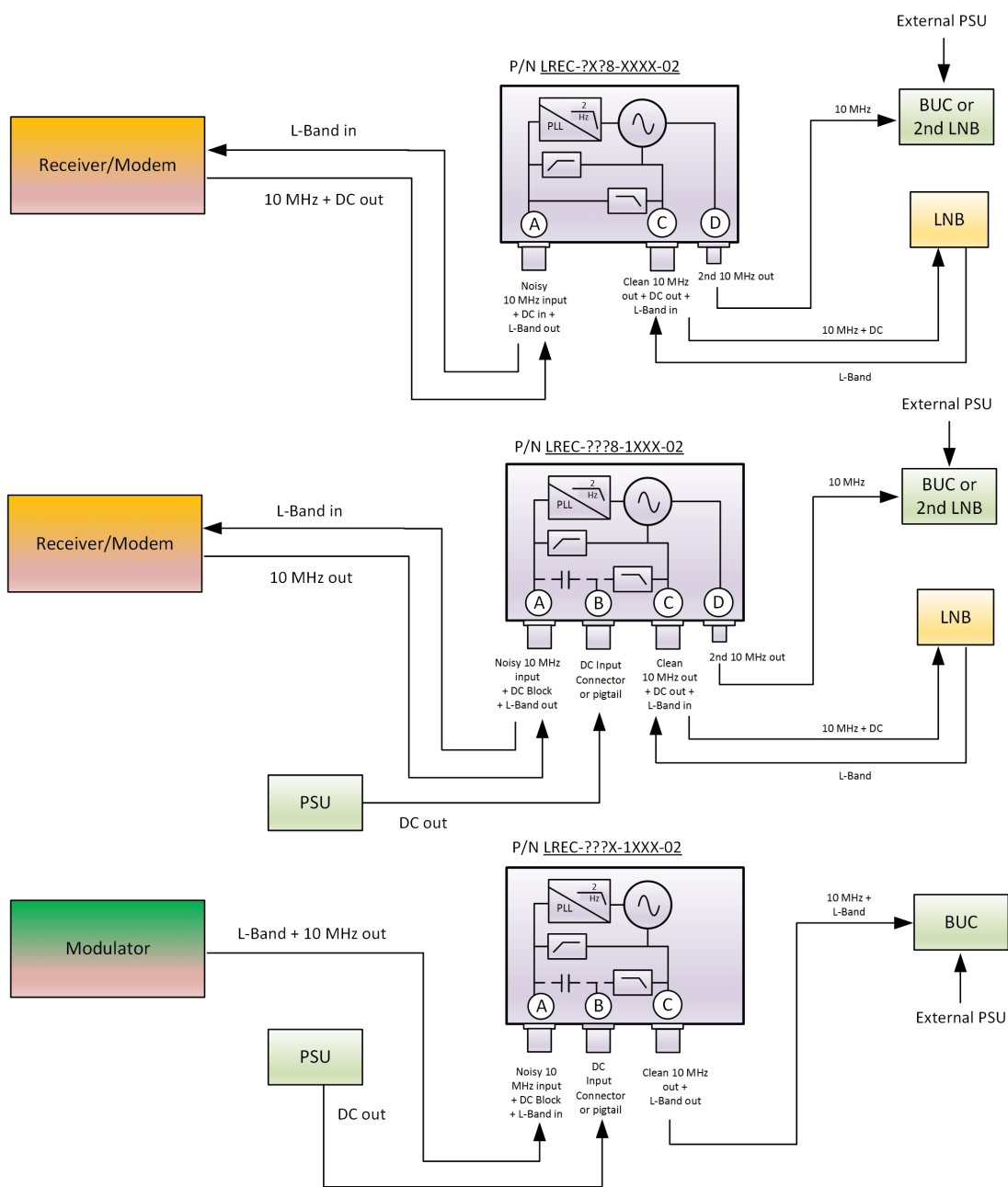

**Part number designation for the 10 MHz recovery oscillator**

Model	Connector A	Sep. DC input B	Connector C	2nd 10 MHz out	DC Block A	DC Block C	Future use	Future use	Version
LREC	?	?	?	?	?	?	X	X	02
0	F	X	No	0	F	X	No DC block		
5	N	0	F	5	N				
8	SMA	5	N	8	SMA	1	DC Block		
		8	SMA						
		9	Pigtail						

Example: L-Band + 10 MHz input + DC block (N), L-Band in + DC Block + 10 MHz out (N), Separate DC input (N), 2<sup>nd</sup> 10 MHz out = LREC-5558-11XX-02

Rev. K

Rev.01-22-5B

Above parameters are generic product family values. For part number specific min./max. values, please consult us.

Specifications are subject to change without notice. Products from Swedish Microwave AB are made for commercial use.

Swedish Microwave AB, Dynamov. 5, S-591 61 Motala, Sweden. Tel: +46 141 216135, sales@smw.se, www.smw.se