

PTA-700 XY Pedestal Tracking ESA

PROFEN's PSA-700 XY pedestal earth station antenna (ESA) was specially designed for tracking LEO, MEO, and GEO spacecraft to use both daily operation and TT&C. The unique design of pedestal eliminates the problem of the overhead keyhole issue encountered in traditional three-axis AZ/EL mount antennas.

Even though the standard design comprises a Cassegrain type dish with FSS type sub-reflector to operate in S and X band, other types of configuration and frequency bands are available upon request as an option.

The pedestal comes with specially developed ACU system capable to operate in various satellite tracking modes including Step Track, TLE-based program track, Time & coordinate based program track and Mono pulse tracking.

The ACU comes with the Outdoor Drive Unit (ODU), which houses most of the pedestal electronics such as power supplies, servos and optionally the Indoor Control Unit (ICU), which has LEDs and Display to show and control various of operation of the pedestal. The ICU is normally located in a system room environment, but it can be supplied with an outdoor IP rated enclosure designed for all environmental conditions.

Key Features

- X/Y axis configuration
- No keyhole at zenith
- Ideal for tracking LEO, MEO and GEO spacecraft
- Precision carbon composite antenna
- Dynamic satellite tracking and accurate pointing
- Backlash free drive system and safety interlock
- Antenna system is available in other frequency bands L, S, C, X, Ku, K, and Ka

Typical Applications

- Earth Observation and Imaging
- Remote Sensing
- Satellite Communication
- TT&C type applications
- Telemetry ground station for UAV and missile applications

PTA-700 XY Pedestal Tracking ESA Specification*

Pedestal Mechanics		Environmental	
Aperture Size	5m—7.5m parabolic dish antennas	Wind Speed	90 km/h wind (Operational) 200 km/h wind (Survival)
Pointing Accuracy	<0.05°	Temperature	-30°C - +55°C (Operational) -40°C - +65°C (Survival)
Acceleration	5°/s ² typical	Humidity	98% Relative Humidity
Velocity	5°/s typical	Driving Rain	Up to 110 mm/hr
Movement	Diagonal in X and Y simultaneously	Solar Radiation	1100 Watt/m ²
Axis Travel	Full hemispheric coverage	De-ice system	Reflector and Feed System
Motors	8kW AC Servo in X and Y axis 3 phase 380 V, max 60A		

Antenna RF Specifications			
Antenna Size	7.3m	S Band Gain	Rx: 43.05 dBi@2232 MHz TX: 40.50 dBi@2100 MHz
Antenna Type	X-Band Cassegrain w/FSS S-Band Prime Focus	S Band G/T	20.91 dB/K @ EL 42°
Frequency Bands	S and X bands	X Band Gain	54.15 dBi@8250 MHz
Frequencies <i>S-Band</i> <i>X-Band</i>	2000-2400 MHz 8000-8500 MHz	X Band G/T	32.80 dB/K @ EL 40°
Polarization and Feed System	RHCP, LHCP with mono pulse coupler	VSWR	1.5:1
Side Lobe Performance	ITU-R S.580-6	Tx to Rx Isolation	85 dB

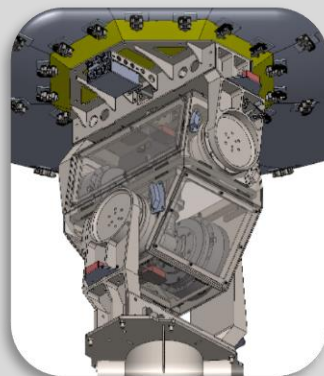
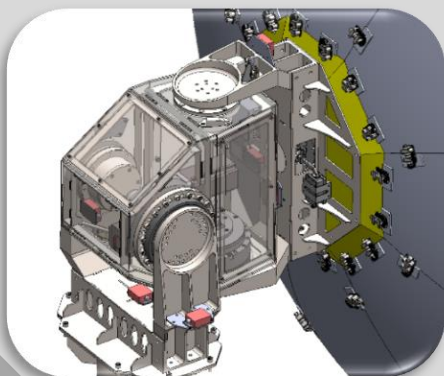

*Specifications is subject to change without notice